

CRAMPON

Pedal assembly instructions:

1) Using supplied red loctite, place a drop of loctite in each pin hole prior to inserting pin.

2) Insert 18mm pins (4) in center edge pin holes.

3) Tighten 18mm pins (4) down until equal parts of the pin are exposed on each side of the pedal.

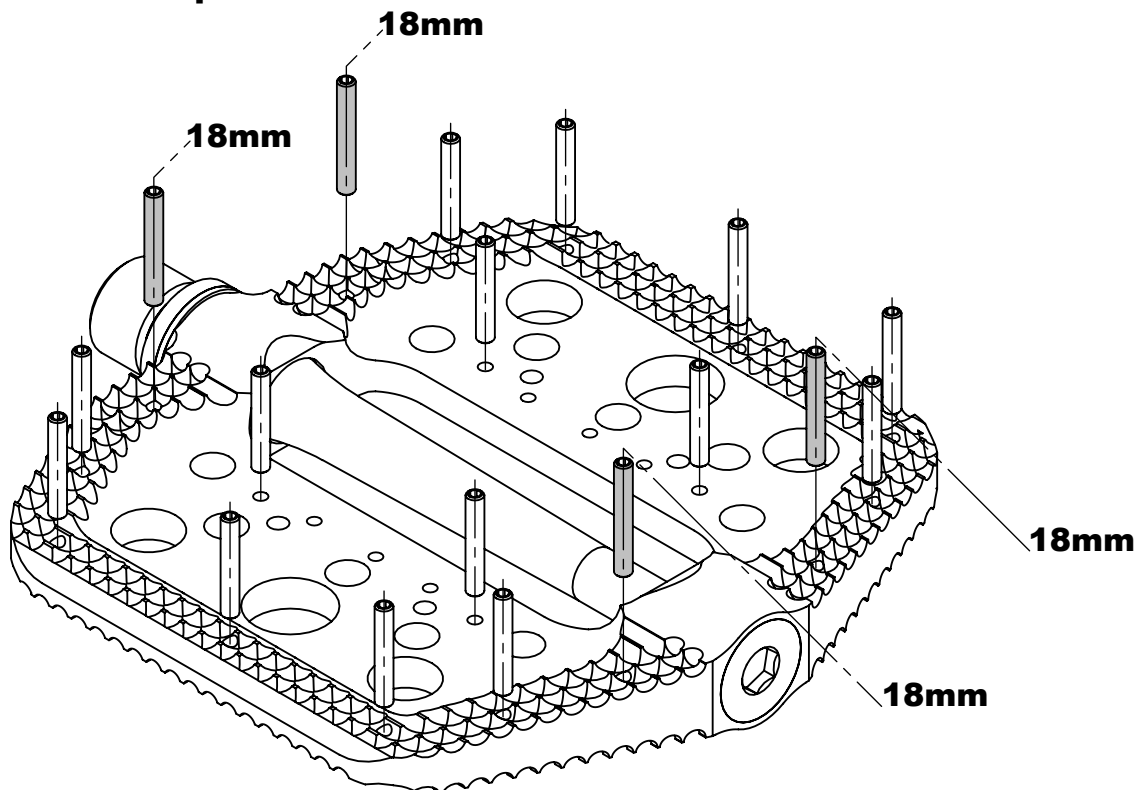

4) Using remaining pin sets 14mm (short) or 16mm (long), fill in remaining holes in the same way. Repeat loctite application on all remaining pin holes.

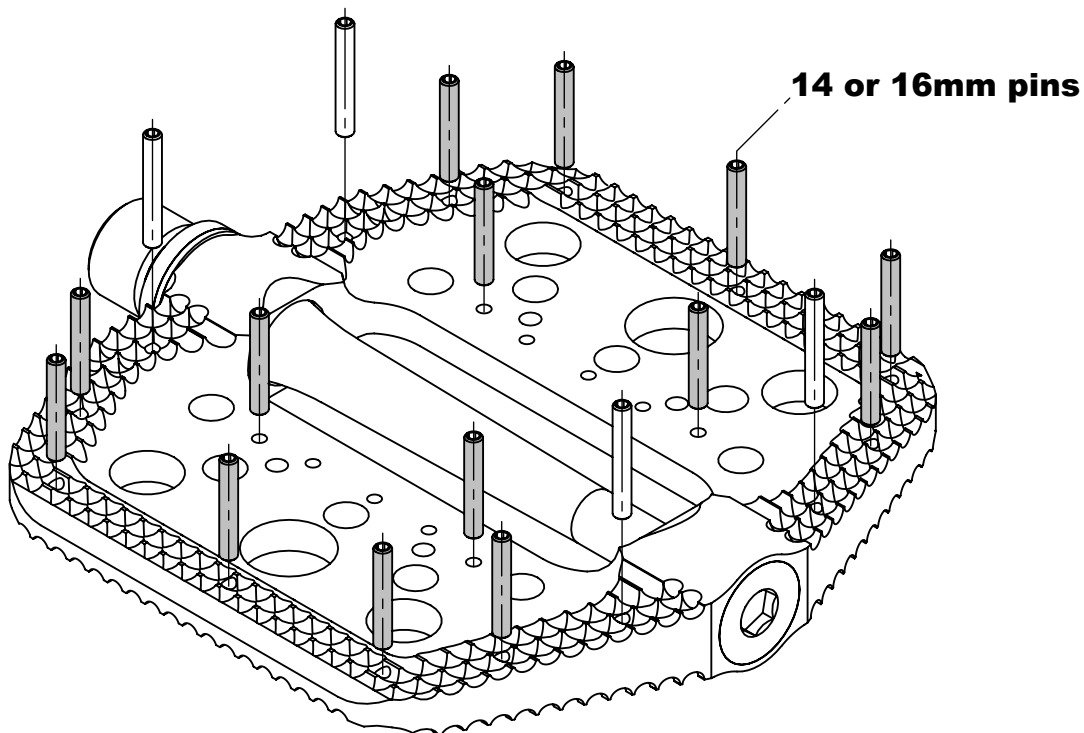

5) Allow loctite to dry overnight before riding pedals.